

QL-51B Mini load Cell

QL-51 miniature sensor are available in the capacities from 50g
Aluminum construction, silicon adhesive sealed, surface anodized and anti-corrosion.
Integral structure and easy installation.
Suitable for electronic balance, electronic platform scale and other electronic weighing devices.



Features:

- ◆ Capacity : 20~200g
- ◆ Defend grade: IP65
- ◆ High accuracy.
- ◆ Aluminum parallel beam
- ◆ Integral installation, Low profile and nice exterior.

Electrical connection and Dimensions:

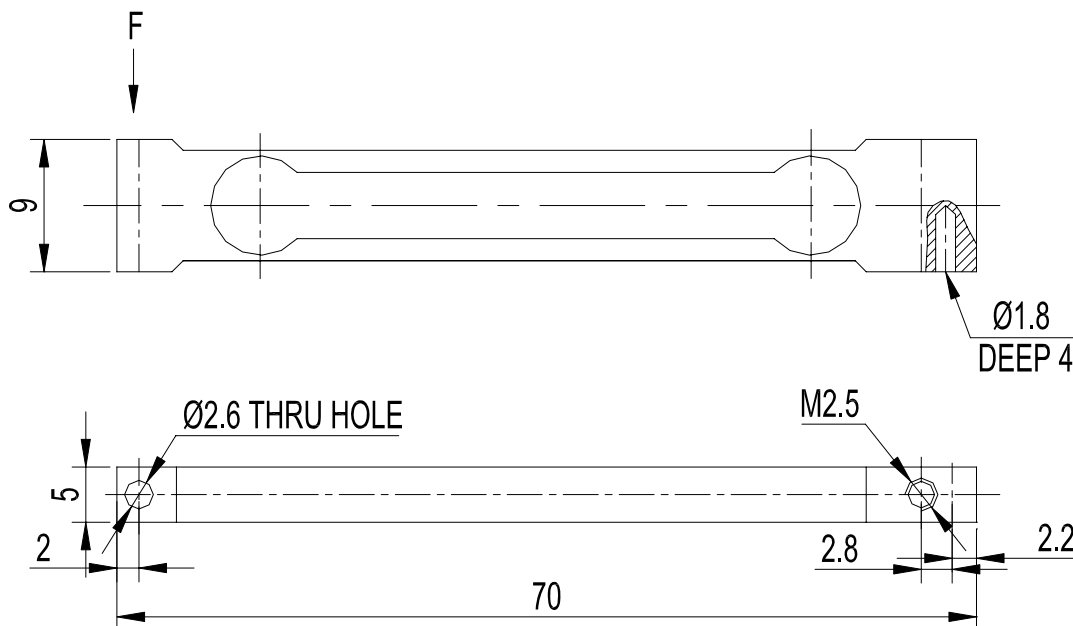

QY Electronic Co Ltd

Address: No. 1032, Xinghan Road, Hantai District, Hanzhong, Shaanxi, China (Mainland)

Website: www.qysensor.com

TEL: +86-(0)916-2257989

E-mail: info@qysensor.com

Zip: 723000

QY Electronic Co Ltd

QL-51B

Technical Specifications

Specifications:		
capacity	g	20, 30, 50, 100, 200
ultimate overload	%FS	150
rated output	mV/V	0.5 ± 0.15
excitation voltage	Vdc	≤ 6
combined error	%FS	± 0.05
zero unbalance	mV/V	± 0.5
non-linearity	%FS	± 0.05
hysteresis	%FS	± 0.05
repeatability	%FS	± 0.05
creep	%FS/5min	± 0.05
input resistance	Ω	1055 ± 10
output resistance	Ω	1000 ± 10
insulation resistance	M Ω	$\geq 2000 @ 50 \text{ Vdc}$
compensated temperature range	$^{\circ}\text{C}$	-10 ~ +40
temperature coefficient of SPAN	%FS/ 10°C	± 0.05
temperature coefficient of ZERO	%FS/ 10°C	± 2.0

Electrical connection:

Excitation+ red Excitation- black Signal+ green Signal- white

Four-core shielded cable with polyethylene. Cable is not connected with elastomer.

The cable length could be chose by customer's application.

QY Electronic Co Ltd

Address: No. 1032, Xinghan Road, Hantai District, Hanzhong, Shaanxi, China (Mainland)

Website: www.qysensor.com

TEL: +86-(0)916-2257989

E-mail: info@qysensor.com

Zip: 723000